

## LUCAS OIL OFF ROAD RACING SERIES UTV RULES

**ALL UTVS ARE SUBJECT TO ALL LOORRS RULES ON PAGES 1-16 OF THE 2010 LUCAS OIL OFF ROAD RACING SERIES RULE BOOK. RULES ARE SUBJECT TO CHANGE AND ADJUSTMENT AS NEEDED IN THE INTEREST OF COMPETITION.**

**\*NOTE TO UTV DRIVERS: PLEASE COME TO THE RACE WITH A HEAD GASKET & TOOLS PREPARED TO PULL THE HEAD FOR MOTOR INSPECTION \***

Unlimited UTV: Heavily modified UTV up to 800cc displacement.

SR1 UTV: Heavily modified Yamaha Rhino, utilizing a Yamaha R1 1000cc engine.

### **UTVR-1 MARKING AND IDENTIFICATION**

- A. All vehicle numbering is subject to approval and is assigned by LOORRS.
- B. LOORRS officials may require a competitor to use a different number to avoid confusion or duplication at an event.
- C. In the event that a number is not visible from the timing and scoring area, the competitor will not be scored. It is the competitor's responsibility to make sure that the number is visible during all race conditions.
- D. Advertising on race vehicles must be in good taste.
- E. Foil or reflective numbers are not permitted.
- F. All LOORRS vehicles are required to have LOORRS stickers on each side of the front of the door area, 4 inches down from the window opening.
- G. LOORRS may require the use of specific sponsor decals.
- H. Team vehicles with the same paint and colors must have distinguishing markings of some kind.

### **UTVR-2 NUMBERS**

- A. Numbers are 600-699 for the Unlimited UTV class.
- B. Numbers are 800-899 for the SR1 UTV class.
- C. Numbers must be applied side by side. No slanted numbers.
- D. Number plates must be white with solid black block style numbers.
- E. Numbers must be located in the following positions:
  - 1. One number on each side of the vehicle, on a number plate mounted high and close to the back of the roof. Minimum number plate size: 10 inches high by 14 inches long. Minimum number size: 8 inches by 1 ½ inches.
  - 2. The back of the vehicle facing the rear, on a number plate. Minimum number plate size: 6 inches high by 8 inches wide. Minimum number size: 5 inches by 1 ½ inches.
  - 3. Roof of vehicle. Minimum number size: 8 inches by 1 ½ inches.
  - 4. Upper left hand corner of windshield area. Minimum number size: 4 inches.

### **UTVR-3 DRIVER MEDICAL ATTENTION**

- A. If a competitor requires medical attention, by track or other medical teams, the medical technician must release competitor before he/she may return to competition. Failure to comply with the advice of the medical technician will result in disqualification from competition for the remainder of the event.
- B. If a driver loses consciousness at any time during an event, the driver cannot compete for at least 7 days or must be cleared by a doctor before returning to competition.

### **UTVR-4 EQUIPMENT**

- A. No passenger is allowed on/in the race vehicle any time the vehicle is in motion.
- B. Race vehicles will not be allowed on the race track without safety and emergency equipment on the premises.
- C. No race vehicle is permitted on the track without approval from a LOORRS official.
- D. No driver will compete in any event with his/her head or arm extended outside of the vehicle.
- E. 1 UTV and 1 pit bike will be allowed per entry. These pit vehicles must be registered with LOORRS headquarters, must be driven in a safe manner, and may not be driven by anyone under 16 at any time.

### **UTVR-5 DRIVER'S WEAR**

- A. One-piece driver suits are required. The suits must cover from the neck to the ankles and to the wrists. All suits must have the SFI label attached and meet SFI Spec 3-2A/5 or higher.
- B. Drivers must wear gloves and driving shoes that meet SFI Spec B. 3.3/5 or higher and have the SFI label attached.
- C. All driver apparel must be clean, in good condition, and free from rips or worn areas.
- D. The designated LOORRS patch will be sewn to the suit on the upper front right breast area, no more than six inches from the top of driver's shoulder. No other racing sanctioning body patches or decals are to be worn on the suit.

### **UTVR-6 HELMETS**

- A. Full face helmets with a Lexan shield are required.
- B. Helmets must be certified to one or more of the following standards:
  - 1. Snell Memorial Foundation SA 2005 or better with a legible Snell sticker attached.
  - 2. SFI Spec 31.1/2005 with a legible SFI sticker attached.
  - 3. FIA 8868 with a legible FIA sticker attached.

### **UTVR-7 EYE PROTECTION**

- A. It is required that drivers wear eye protection in the form of Lexan shields.

#### **UTVR-8 SEATS**

- A. Only manufactured race seats are permitted. Custom manufactured aluminum seats must be approved by LOORRS.
- B. All seats, rib protectors, leg extensions, and head rests must be padded.
- C. Headrests are required and must be a minimum of 36 square inches in area.
- D. Passenger seats are not required.
- E. All seats must be securely mounted to frame of vehicle and properly reinforced in such a manner as to keep seat from moving in relationship to the frame.

#### **UTVR-9 SEAT BELTS & SHOULDER HARNESSSES**

- A. A quick release lap belt not less than three inches wide is required. Both ends of the lap belt must be fastened to the roll bar cage. Bolt in style belts must be fastened with high quality graded bolts, not less than  $\frac{3}{8}$ ". Clip in style belts must be cotter pinned or safety wired.
- B. Shoulder harnesses are mandatory. Harnesses must be no less than three inches wide and must come from behind driver's seat. When crossing the roll cage the harness must pass through a steel guide welded to the cage that will prevent the harness from sliding from side to side.
- C. A crotch belt is mandatory and must be securely mounted to the lower seat frame or roll cage at the bottom, and to the lap seat belt on the top.
- D. Sternum straps are not allowed.
- E. At any place the lap belt, harness, or crotch belt passes over any substance that could cause cutting of the belt, the belt must be rolled, padded, or have a grommet installed.
- F. All seat belts and shoulder harnesses must connect at the lap belt with a quick release buckle.
- G. Seat belts must be certified to SFI specs 16.1 or 16.5 and dated by the manufacturer. Belts must not be used beyond two years after stated date.
- H. Seat belts may be rejected by LOORRS officials if dirty, frayed, oily, greasy, or otherwise considered unsafe by officials.

#### **UTVR-10 HEAD & NECK RESTRAINTS**

- A. Head and neck restraints are mandatory for all classes. D-Cell, R3, and Hybrid are the only devices currently approved. Any other device must have LOORRS approval before use.

#### **UTVR-11 GAS PEDALS**

- A. All vehicles must have a flat full support gas pedal with a toe hook.
- B. Toe hook must enable the driver to pull back on the pedal with foot in the event of a stuck throttle. See Lucas Oil Off Road Racing Series Rule Book page 43 for diagram.
- C.

#### **UTVR-12 FIRE PROTECTION**

- A. It is mandatory that all teams have 1 fully charged 10 pound dry chemical ABC fire extinguisher per UTV in their pit area at all times.

- B. Bulk fuel storage is prohibited in the pits.
- C. Metal drums, electric fuel pumps, and metal hand pumps are not allowed.
- D. Fuel jugs must be plastic and DOT approved.
- E. Plastic fuel pumps are the only fuel pumps allowed in the pits.
- F. Every pit must have "no smoking" signs posted every 30 feet at the front of the pit closest to the public walkways.
- G. Any awning over 100 square feet must have a valid flame certificate.
- H. All UTVs must carry a portable 1 pound ABC class dry chemical or equivalent Halon type fire extinguisher. Extinguisher must have a gauge, be fully charged, and easily accessible from inside the vehicle with current fire marshal's seal and attached label.
- I. LOORRS highly recommends that UTVs have a remote, on board, 5 pound minimum fire suppression system.

#### **UTVR-13 ROLL BAR PADDING**

- A. Any roll bar that may come in contact with the driver must be covered with roll bar padding.
- B. All roll bar padding must be certified to SFI spec 45.1 or better.

#### **UTVR-14 SAFETY NETS**

- A. Window nets must be certified to SFI spec 27.1 and have the manufacturer's SFI label attached. Honeycomb mesh or ribbon style window nets are acceptable. The ribbon type should be made from exactly 1 inch nylon material with a maximum 1 ¼ inch square opening between the ribbons.
- B. The window net must fill the entire window opening of the race vehicle to allow no more than 3 inches access to the drivers.
- C. All window net mounts must be welded to the roll cage. The window net, when in closed position must fit tight and be secured with a safety belt type of latch.
- D. Velcro is not permitted.
- E. The window net latch must be located at the front top of the window opening and must allow access to the main on/off switch.
- F. Spring type mounting of nets on the top or bottom is not permitted.

#### **UTVR-15 ROLL CAGE & CHASSIS**

- A. All vehicles must utilize the stock chassis and maintain stock appearance. The stock chassis (frame) is defined as the main lower rails running along the inner sides of the UTV and the front and rear tubes that connect them. The chassis may be modified for durability and strength but must retain the stock width, length, and configuration. Any modifications must be pre-approved by LOORRS officials.
- B. No bolts on connections to chassis are allowed. All joints must be welded and attached to the frame securely.

- C. After market roll cage required.
- D. Cages must be constructed with one front vertical hoop, one rear vertical hoop, two interconnecting top bars, two rear down braces, one diagonal brace, and all necessary gussets.
  - 1. Two top interconnecting bars must be placed as far to the outside of the top part of the front and rear hoops as possible.
  - 2. Rear down braces and diagonal brace must angle a minimum of 30 degrees from vertical. At the bottom of the diagonal brace there must be a cross member of the same tubing material and dimensions as the hoop.
- E. There must be a minimum of 3 inches clearance between driver's helmet and roll cage.
- F. Gussets must be installed at all major intersections, including diagonal and rear down braces, where single weld fractures can affect occupant's safety.
- G. Gussets may be constructed of minimum .090 inch x 3 inch x 3 inch flat plate or tubing gussets made of same material and thickness as roll cage.
- H. Roll cage terminal ends must be attached to a frame or body member that will support maximum impact and not shear or allow more than 1 ½ inches of movement in the cage terminal end.
- I. Minimum tubing diameter and thickness is 1 ½ inch diameter by .095.
- J. Roll cage material must be dom or 4130 chromoly.
- K. All tubing, welds, gussets, and roll cage construction must be approved by LOORRS.
- L. Top left half of roll cage above driver's head must have 1 ½ inch x .095 inch 'X' diagonal bracing bars and/or be covered with .125 inch minimum aluminum plate.
  - a. If plate is used, a single diagonal bar is sufficient.
  - b. Plate must be attached with 2 bolts on each of the four sides.
- M. Entire roof must be covered with sheet metal or .063 inch minimum aluminum.
- N. SR1: Vehicles must utilize the stock Rhino chassis.

#### UTVR-16 DOORS

- A. Door area must be covered with sheet metal or a minimum of .063 inch thick aluminum.
- B. Doors must have 'X', 'A', or Ladder design bracing designed to provide maximum protection to the driver.
  - 1. X or A designs must use a minimum 1 ½ inch diameter by .095, 4130 chromoly or DOM.
  - 2. Ladder design must use a minimum 1 ½ inch diameter by .095 for main rails and 1 ¼ inch by .095 for rungs.

#### UTVR-17 DRIVER COMPARTMENT

- A. Driver must be able to enter and exit, unassisted and with great ease, the driving compartment with the vehicle in any position. Firewalls and/or bulkheads must separate the driving compartment from any fuels, engine fluids, and acids.

### UTVR-18 MEASUREMENTS & WEIGHT

- A. All measurements will be performed with LOORRS technical instruments and gauges. LOORRS officials determine all measurements and center points.
- B. The maximum width of the vehicle, measured from outside of tire to outside of tire is 77 inches.
- C. The maximum overall wheelbase from spindle to spindle can be increased to 8 inches over stock dimensions.
- D. The minimum vehicle weight is 1400 pounds including driver .
- E. **Unlimited:** Minimum weight for the Polaris RZR and Yamaha Rhino running in the Unlimited UTV class is 1325 pounds.

### UTVR-19 WINDSHIELD AREA

- A. UTVs must have complete left half of windshield opening covered with a LOORRS approved rock guard. Rock guard must have a minimum 1/8 inch rod and a maximum 1.5 inch square opening welded at each intersection.
- B. A 7 inch by 10 inch section may have vertical bars only. See diagram.

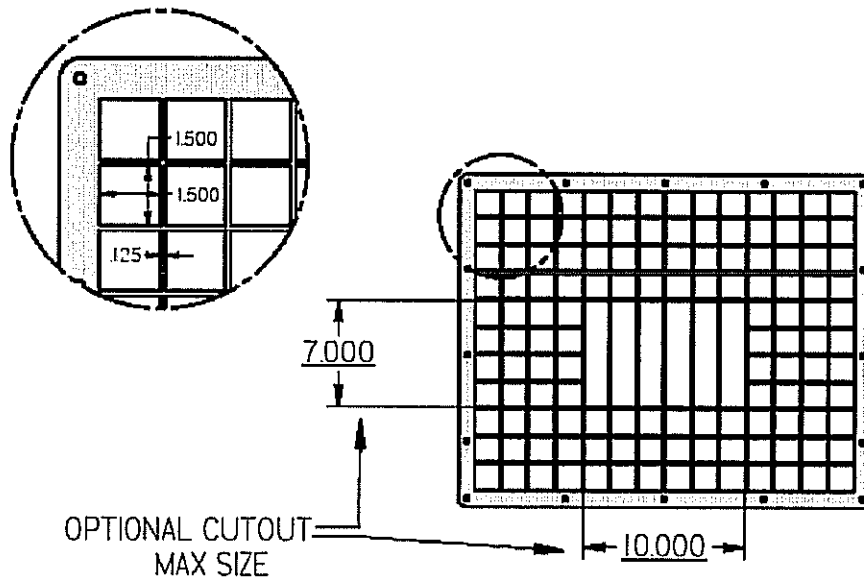

### UTVR-20 FENDERS

- A. Fenders must be securely attached to vehicle. The removal of fenders during competition during any reason other than damage incurred during the race will result in disqualification.
- B. Fenders must be attached in such a fashion as not to create a pointed or sharp extrusion when removed. A loop body mounting bracket construction is mandatory.
- C. Additions to the body of the race vehicle, such as fins, scoops, wings, and other extruding additions will not be permitted.

- D. Vehicles must maintain an appearance similar to the stock UTV.

#### **UTVR-21 BUMPERS**

- A. Vehicles must have front and rear bumpers. LOORRS officials must approve all bumpers.
- B. No hazardous bumpers, nerf bars, frame heads or other protruding objects from vehicles are permitted.
- C. Rear bumper must be secured to frame using a minimum 1 ½ inch diameter .095 chromoly.
- D. Bumpers must be designed in such a way as to inhibit two vehicles from becoming locked together.
- E. Ends must be capped and rounded with no sharp edges.
- F. Minimum front bumper width is 35 inches.
- G. Side nerf bars are recommended.

#### **UTVR-22 SKID PLATES/FLOORBOARDS**

- A. Skid plates designed to reasonably protect the front suspension, steering, and brake components are recommended on all vehicles. Plates must be made of metal and be securely attached.
- B. Stock UTV floorboards are acceptable but extra protection made of metal or aluminum is highly recommended.

#### **UTVR-23 SUSPENSION**

- A. All A-arm mounting points must remain in the stock location and position as delivered from the manufacturer, however they may be reinforced for strength.
- B. **SR1:** Stock suspension, or any suspension less than 6 inches over stock will not be allowed.

#### **UTVR-24 STEERING**

- A. All steering components must be in good condition and proper working order. Drag link and tie rod ends must be secured with a cotter pin in each one.
- B. Power steering is permitted.
- C. LOORRS officials must consider steering reasonably safe before vehicle is permitted to compete.

#### **UTVR- 25 SHOCKS**

- A. There must be at least one and only one shock absorber per wheel in working condition at the start of the race.
- B. Shock absorber mounting points may be moved.
- C. **SR1:** Max shock length not to exceed 10 inches of shaft travel.

#### **UTVR-26 BUMP STOPS**

- A. Suspension bump stops must be of the solid type.

#### **UTVR-27 TORSION SYSTEM**

- A. The only torsion system that is acceptable is a coil-over shock.

#### **UTVR-28 WHEEL SPACERS**

- A. Wheel spacers are permitted.

#### **UTVR-29 BRAKES**

- A. Brakes must be in safe working condition and be able to apply adequate force to lock up all four tires. Brakes must remain in safe working condition during entire event.
- B. Turning or cutting brakes are not permitted.

#### **UTVR-30 ENGINE**

- A. All vehicles must use stock engine cases and cylinder head. LOORRS reserves the right to mark engine blocks prior to event.
- B. All vehicles must use same fuel delivery system as stock and designed by factory. Electric fuel pumps are permitted in accordance with LOORRS safety requirements for fuel pumps.
- C. **Unlimited UTV:** Engine displacement not to exceed 800 cc.
- D. **SR1:**
  - a. Stock Yamaha R1 engine (year 2002-2008) is required.
  - b. No modifications of any kind can be made to engine.
  - c. No modifications to throttle bodies can be made.
  - d. R1 tip over sensor must be left intact and in working order.
  - e. Engines must be mounted between the driver and passenger seat locations utilizing the spec SR1 mounting plate.

#### **UTVR-31 SUPERCHARGERS & TURBOCHARGERS**

- A. Superchargers or turbochargers are not permitted.

#### **UTVR-32 AUXILIARY EQUIPMENT**

- A. All vehicles must start race with a functional generator or alternator, fan, water pump (water-cooled vehicles), and a complete functional electrical system.

#### **UTVR-33 IGNITION**

- A. All vehicles must have a positive action on/off switch in good working order. Switch must be labeled "ignition on/off", have a red circle around it, be located on the left hand side of the

dash panel, and must be accessible from the outside of the race vehicle. Red circle must be at least 1 inch wide.

- B. All electric fuel pumps with independent switches must be labeled "fuel on/off" and be within easy reach of the driver and accessible from the outside of the vehicle.
- C. Aftermarket CDI boxes/ECUs are permitted with LOORRS approval.

#### **UTVR-34 BATTERIES**

- A. Batteries must be securely mounted with metal-to-metal tie downs.
- B. Wetted fiber or gel cell batteries only. Liquid lead acid batteries are not permitted.
- C. Batteries may be located in the driver's compartment with an adequate firewall or factory engine cover.

#### **UTVR-35 COOLING**

- A. Oil coolers, transmission coolers, and radiators located ahead of the driver or in the passenger compartment must have a shroud that will prevent liquids from blowing back or leaking onto the driver in the event of a rupture or leakage.
- B. All hoses running through the driver compartment must be shielded. Steel braided hose does not constitute a shield.

#### **UTVR-36 EXHAUST**

- A. Exhaust systems must be a minimum of 6 inches away from fuel lines and 18 inches away from fuel filler.
- B. Muffler must meet a maximum decibel of 100 as measured 50 feet from track side.

#### **UTVR-37 STARTER**

- A. All vehicles must be self-starting by use of an onboard electric starter.

#### **UTVR-38 ENGINE REPLACEMENT**

- A. Engines may be replaced during a LOORRS event only if competitor has notified LOORRS officials.
- B. Engine change will result in a starting position change.

#### **UTVR-39 FUEL CELLS**

- A. All fuel cells must be LOORRS approved.
- B. LOORRS will reject any previously approved fuel cell, which appears to be defective, damaged, or not in proper condition.

- C. No pressure systems will be allowed. Any concealed or not concealed pressure type containers, feed lines or actuating mechanisms will not be permitted, even if inoperable.
- D. Icing, Freon type chemicals, or refrigerants may not be used in or near the fuel system.
- E. The use of a commercially manufactured fuel cell is mandatory. Aluminum cans with foam inside are not allowed.
- F. Safety fuel cells shall consist of a bladder enclosed in a smooth skinned container. The container shall be constructed of 20 gauge steel, 0.060-inch aluminum or 0.125-inch Marlex. Rotary molded polymer cells are acceptable.
- G. No material other than standard foam as provided by the fuel cell manufacturer is permitted.
- H. Fuel cell must have a chassis or body cross member of substance between the fuel cell and driver and be protected from ground obstacles.
- I. Fuel cells must be dated from manufacturer. Fuel cells will become obsolete five years after date of manufacture and must be replaced.
- J. All fuel cell fillers and vents must have check valves installed.
- K. Fuel filler lines and positive-locking non-vented fuel filler caps must be located and secured in such a manner as to prevent them from being knocked off or opened during movement, rollover, or impact.
- L. A splash shield must be in place to direct any spill away from the driver, motor, and motor exhaust. A body panel is considered a sufficient splash shield.
- M. Fuel cell cannot be vented into the driver's compartment of any vehicle.
- N. All mountings must be LOORRS approved. Fuel cell must be mounted to chassis and cannot be mounted on skid plate.
- O. Any fuel cell mounted in the passenger compartment area must be fully enclosed with sheet metal or aluminum.
- P. An 8 inch by 8 inch fire access door is required on top of the fuel cell cover. This door must be painted red and labeled FIRE DOOR.
- Q. Any battery or electrical components mounted in the passenger compartment with the fuel cell must be separated by sheet metal or aluminum.

#### **FUEL VENT ROUTING**

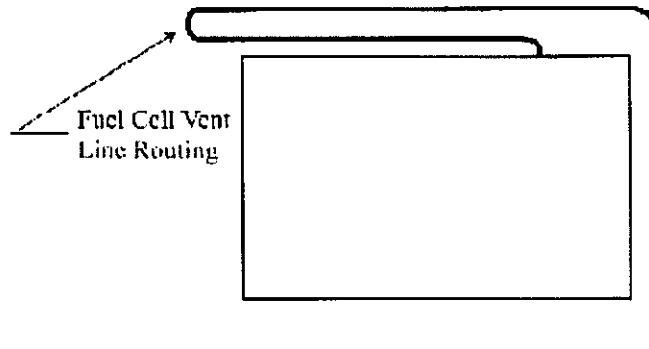

All fuel cell vents and lines must come out of the top of the fuel cell as pictured.

#### UTVR- 40 FUEL

- A. Fuel shall be automotive gasoline only.
- B. Gasoline shall not be blended with alcohols, ethers, or other oxygenates, and it shall not be blended with aniline or its derivatives, nitrous compounds, or their nitrogen containing compounds.
- C. Cooling of any type of fuel is not permitted during competition.
- D. In the event an "official fuel" is named, LOORRS will sample the actual fuel provided at the track by the fuel supplier and that sample will become the benchmark from which all competitors samples will be judged.
- E. LOORRS has the right to sample a competitor's fuel at any time. All samples will be impounded for observation and/or testing by LOORRS or outside laboratories at LOORRS discretion.
- F. No nitrous oxide.
- G. If LOORRS officials suspect maskers in the fuel, chemical testing will be conducted at possible expense to the competitor.
- H. Penalties for use of hazardous chemicals will be severe including fine, and/or reduction of points, and/or suspension.

#### UTVR-41 TRANSMISSION

- A. **Unlimited:**
  - 1. Every vehicle must use the stock transmission and clutch design.
  - 2. The stock rear differential must also be used.
  - 3. All vehicles must have a functional reverse gear.
- E. **SR1:** Must use stock R1 transmission. Vehicle must use direct chain drive.

#### UTVR-42 CLUTCH

- A. **SR1:**

- a. Must use stock R1 clutch design.
- b. After market clutch plates and springs will be allowed.
- c. Must utilize either a clutch pedal mounted on floor or mounted on shifter, as well as a stick shift style shifter.
- d. Electric paddle shifters and automatic clutch systems are not allowed.

#### **UTVR-43 WHEELS & TIRES**

- A. Maximum tire size is 30 inches outside diameter.
- B. No more than 1 tire per corner is permitted.
- C. Tires will be visually checked and must be considered reasonably safe by LOORRS prior to competing.

#### **UTVR-44 FASTENERS**

- A. All components on the vehicle's suspension system, chassis, and running gear must be secured with S.A.E. Grade 8 or better nuts and bolts.
- B. Bolts must be secured with either lock nuts, lock washers, cotter pins, or safety wire and have at least one full thread showing through the nut.

#### **UTVR-45 HOSES**

- A. All fuel and brake line hoses including metal lines and fittings must be clamped and/or safety wired.

#### **UTVR-46 MIRRORS**

- A. Rear view mirror with at least 6 square inches of mirror surface and a reasonably unobstructed view of area behind vehicle is recommended on all vehicles.

#### **UTVR-47 RADIOS**

- A. Radios must be of two-way voice communication type only. Each race team is responsible for meeting FCC requirements.
- B. Radio communications between drivers is not permitted.
- C. All radio frequencies must be approved and reported to LOORRS prior to their use.
- D. All race vehicle radio communication systems must be approved by LOORRS.
- E. See section 5 of LOORRS General Rules for spotter requirements.
- F. Spotters are required for all race teams.

#### **UTVR-48 TRANSPONDERS/TIMING**

- A. Remote score timing devices will not be permitted by teams, owners, or anyone associated with an entry, unless approved by LOORRS.
- B. All teams are required to purchase remote timing transponders. Transponders can only be purchased through LOORRS and numbers must be recorded with LOORRS officials.
- C. Drivers are responsible for the charging and installation of all transponders. Any entry without a properly installed, functioning transponder may not be scored and may be subject to further penalty.
- D. Transponders must be mounted 10 inches back from the leading edge of the front bumper on the passenger side.